



Trisomy 18

A Handbook for Families



Support Organization for
Trisomy 18, 13 and Related
Disorders

3rd Edition

Trisomy 18

A Handbook for Families

E-Book Version, 2014

Carol M. Stenson, Ph.D.

Professor of Special Education, Emerita
Idaho State University

Steven E. Daley, Ph.D.

Professor of Special Education
California State University, Sacramento

Kris Holladay

Founder of the Support Organization
for Trisomy 18, 13 and Related Disorders

Patricia A. Farmer, M.Ed.

Regional Special Education Consultant
Idaho State Department of Education, and
Instructor of Special Education
Idaho State University

Copyright © 2005

Support Organization for Trisomy 18, 13 and Related Disorders (SOFT)

Third Revised Edition. Copyright 2014. This e-Pub version has had minor updates applied in 2014. These mostly reflect updated references, links and occasional typographical corrections.

All Rights Reserved

ISBN 1-889843-72-5

Originally Published by the Media Center, Munroe-Meyer Institute,

A University Center for Excellence in Developmental Disabilities Education, Research and Service.

University of Nebraska Medical Center, 985450 Nebraska Medical Center, Omaha,
Nebraska 68198-5450



This book is dedicated to Kari Deann Holladay

September 8, 1977 – June 3, 1998

Trisomy 18

Precious daughter of Hal and Kris Holladay

“Trisomy 18, A Handbook for Families” is also SOFTLY dedicated to the memory of Beth Fine. Beth was instrumental in the original printing of this Trisomy 18 book and will remain in our hearts forever.

Acknowledgments

The authors wish to acknowledge Beth Fine, Karen Greendale, Kris Holladay and John Carey, authors of the original *Trisomy 18: A Book for Families*. Their support of this revision is appreciated. Our thanks also to John Carey for providing the karyotypes illustrating trisomy 18.

Many of the quotations by parents used throughout this book are from letters published in *The Soft Touch*, a newsletter published by the Support Organization for Trisomy 18, 13 and Related Disorders. Our thanks to these parents and to the many others who have offered their support, photographs and suggestions.

Bruce Buehler, M.D., Mike Leibowitz, Ph.D. and the Media Center of the Munroe-Meyer Institute, University of Nebraska Medical Center, Omaha, provided invaluable guidance and assistance during the preparation of this guidebook.

Finally, we wish to acknowledge Hal Holladay, Kris's husband and Kari's dad, for his support, strength and love.

Contents

Acknowledgments

Trisomy 18: A Guidebook for Families

What does a diagnosis of trisomy 18 mean for you and your child?

How do you know your child has trisomy 18?

Chromosomes and karyotypes

Figure 1 – Normal Union

Figure 2 – Meiotic nondisjunction

Figure 3 – Karyotype of normal female

Figure 4 – Karyotype of female child with trisomy 18

What are the educational opportunities for your child?

What else do we need to know?

Appendix A

Organizations

Additional Readings

Glossary of Terms

Trisomy 18: A Handbook for Families

When your Physician first tells you that your baby may have trisomy 18 (*Edward syndrome*) or that this diagnosis is suspected, you will be overwhelmed with questions. The first question usually is, “*What is trisomy 18*”? This guidebook was written to answer some of these questions, to share insights of other parents of children with trisomy 18 and to give hope for the best possible outcome for your child.

What does a diagnosis of trisomy 18 mean for you and your child?

When a physician diagnoses trisomy 18, parents are usually told that the condition is almost always fatal. Even given this diagnosis, parents still want to know what the possible life expectancy of their baby might be. While the literature on trisomy 18 indicates that 80 – 90 percent of live births die in the first year of life, children are not statistics. The files of the Support Organization for Trisomy 18, 13 and Related Disorders (SOFT) indicate a small number of children with trisomy survive much longer than initially expected. Your baby with trisomy 18 has already demonstrated a strong will to survive by just being born. It is important for you to recognize that, in the absence of any immediate life-threatening conditions, the current life expectancy predictions may not be very applicable.

What we remember most about that day was the incredible fear. John and I held each other and Kyle between us. We were together and yet so terribly alone with our fear – fear of the present, fear of the future. We had experienced the death of our dreams for a little boy we had longed for. We, like all of you, experienced every parent’s nightmare.

Immediately after birth, there is a good chance your child will have to spend time in the neonatal intensive care unit, or NICU. This can be a frightening experience for parents who are not familiar with the routines or equipment in the NICU.



Kayne, 1 day old.

While all the equipment you see and all the techniques performed may seem forbidding, remember they may be your baby's lifeline for the first days. Equipment you might see in the NICU includes:

- Open beds with overhead heaters designed to keep your baby's temperature regulated. A heat sensor attached to your baby's skin tells the system when to cool or heat in response to changes in room temperature.
- "Bili lights" over an open bed to correct jaundice, or hyperbilirubinemia, common to premature babies.
- Continuous positive airway pressure, or CPAP, a system in which air is forced into the baby's nose through tubes to assist in breathing.
- Respirators that actually take over and breathe for the baby when the baby can't breathe independently. One tube is placed into the baby's mouth with the other attached to the machine to pump oxygen according to the baby's needs.
- Heart and breathing monitors with buzzers to alert NICU nurses when your baby is having a breathing problem.

It is also important to be involved with your baby during the first few days. Nurturing can and should begin in the neonatal unit. If your baby's physical condition allows it, hold your baby. While every family must make individual decisions regarding medical interventions and the depth of involvement with the newborn, initial stimulation of the infant is a very important part of the infant's growth and bonding process.

At first I was afraid to touch her, to get to know her, to let her into my heart if she was going to leave me. But then I touched her and found she was already in my heart. Then I had to hold her, kiss her and love her. My heart began to ache. I couldn't imagine a day without her.



Ryan, 6 months old.

Since trisomy 18 occurs in only approximately 1 in 6,000 live births, it is a relatively rare disorder. Many physicians are not familiar with the syndrome and must rely on medical books and the current medical literature to develop a prognosis for your baby. Much of the commonly available literature is quite dated and does not indicate there are surviving children with trisomy 18. In fact, of the 10% who survive their first year, some children live into their teens and twenties. However, these individuals encounter serious medical and developmental challenges throughout life. Because so much depends on what physical problems your baby has and what other life-threatening conditions may be present, an accurate prognosis may be impossible to make.

Doctors tend to treat the rule, not the exception. With help, we may be able to change that by drawing on information and experience.



Paige, 39 years old, and Barbara Bush.

We urge you to discuss your emotions as you face the inevitable decisions regarding your child's medical care. You are not alone. The Support Organization for Trisomy 18, 13 and Related Disorders (SOFT) is a network and professionals involved in the support of persons with chromosomal anomalies. This group can provide you with support and information needed when difficult decisions must be made (see Appendix A).

We arrived at the decision for minimal treatment through much soul searching and discussion with friends and professionals. For us, the decision is an act of love for Peter and for our family.

After being told there is a strong possibility your child will not survive and will certainly be seriously impaired, you are faced with the question of whether or not to bring the baby home. Many hospitals and physicians encourage the family to take their child home and enjoy whatever quality time is available. Others advise that the baby be left at the hospital. Ultimately, the final decision rests with your family. In any case, it probably will be necessary for your baby to remain in the hospital until the essential and appropriate care is given and the baby's condition is stable.

Naomi stayed in the nursery for three weeks. We brought our guitar in with us and sang to her daily. Toward the end of the third week, Naomi's apnea spells worsened, occurring every five to ten minutes. Fearing she would die without ever going home, we prayed about taking her home that day. God affirmed it was time for Naomi to go with us.

When it is time to take your baby home, the nurses in the neonatal intensive care unit will work carefully with you to ensure that you are able to take care of your baby. You may need equipment to monitor the baby's heartbeat and breathing. If a cleft palate makes nipple feeding difficult or impossible, you may be trained how to feed your baby using a tube, a technique known as *gavage* feeding.

You and your physician may decide to feed the baby through a tube inserted directly into the stomach called a *gastrostomy*. Whatever your baby's medical condition, insecurities about feeding remain a major cause of parental anxiety. Be sure you have sufficient support from a specialist until you are comfortable with this aspect of your child's care.

You and your physician may decide to feed the baby through a tube inserted through the skin and stomach wall, directly into the stomach, called a *gastrostomy*. Whatever your baby's medical condition, insecurities about feeding remain a major cause of parental anxiety. Be sure you have sufficient support from a specialist until you are comfortable with this aspect of your child's care.

Perhaps the most frightening symptom for parents is *apnea*. Apnea is breathlessness or breath holding and is most common in infancy, although some children continue to display apnea throughout their lives. Apneic spells vary in duration. For some

children, slight stimulation is sufficient to induce breathing. For others, cardio-pulmonary resuscitation (CPR) may be required to restore breathing. You may have apnea monitoring equipment in your home, depending on the severity of this problem with your baby. If it is your decision to intervene, all of the baby's primary care givers should be well trained in CPR techniques.

Caitlyn has changed my life for the better and made me realize what is really important in life. Through giving and receiving love, she accomplished a lot in her six months of living. She has given me happiness and she has given me sorrow, but if I had a choice I would do it all over again, just to have Caitlyn.

How do you know your child has trisomy 18?

Although most children resemble their parents, there are certain significant features of a child with trisomy 18 that will immediately alert an informed physician or pediatrician. Some of these characteristics will not affect the baby's life, but will simply aid in the complex task of diagnosis. Some children will have potentially life-threatening complications. It is important to understand that the description of a syndrome includes all possible related disorders, but that most children with trisomy 18 do not have all of the clinical symptoms.



Jillian, 5 years old.

We found out about Caitlyn's diagnosis when she was nine days old. When the tests came back showing trisomy 18, the doctors were very surprised, but not as surprised as Tom and me. We had never heard of trisomy 18 before, but then, who has until they find out their own child has this condition?

Infants born with trisomy 18 can have low birth weight, even when the pregnancy is full-term; a weak cry, and decreased response to sound. There is often a history of decreased fetal activity, excess of fluid in the fetal sac, a small placenta and a single umbilical artery (there are normally two arteries and one vein).

Possible malformations of children with trisomy 18 include a very small head (*microcephaly*) with prominent fullness in the back of the skull. The baby may have short eyelid fissures and *epicanthal folds*, or an overlap of skin in the inner corner of the eye. Children with trisomy 18 usually have a small mouth and an unusually small jaw. Cleft lip and/or cleft palate are common. There may be excess skin folds, especially over the back of the neck.

Children with trisomy 18 usually have clenched fists with the index finger overlapping the third and fourth finger. The big toe is shortened and frequently bent backward (*dorsiflexed*). There are club feet, rocker-bottom feet, webbed fingers and toes (*syndactyly*), and, occasionally, underdeveloped or absent thumbs.



Doreen (D.J.), 1 year old.

Chandra Lynn was born by C-section and had typical trisomy 18 anomalies: back of the head was prominent, small mouth and head, clenched fists, club foot, underdeveloped nails, congenital anomalies of the lungs, horseshoe kidneys, and liver protrusion into the diaphragm. When I was told this in recovery, I was sure they had the wrong room. It was then I was told my baby girl was going to die! Why, I thought, with all the modern technology, was my baby going to die?

Besides these obvious features, almost 90% of all children with trisomy 18 have some type of heart defect. The three most common heart defects are *ventricular septal defect* (VSD), *atrial septal defect* (ASD) and *patent ductus arteriosus* (PDA).

With *ventricular septal defect*, there is a hole between the lower chambers of the heart that prevents the heart from pumping blood correctly. A heart murmur is generally heard with this congenital defect.

Atrial septal defect is a condition in which there is a hole between the two upper chambers of the heart that makes it difficult for the heart to pump sufficient oxygen-rich blood to the body's tissues. A heart murmur is almost always heard with this defect.

Patent ductus arteriosus is a congenital heart defect in which a duct of the heart fails to close, resulting in an abnormal direction of blood flow.

In addition to these problems, there may be other medical difficulties that could require surgical intervention. These include *spina bifida*, a condition in which there is a malformation of some of the bones (*vertebrae*) of the spinal column. In the area of the malformation, there is often an opening in the infant's back.

In some cases of spina bifida, only the covering of the spinal cord protrudes from the opening created by the vertebral malformation. This condition is known as *meningocele*. In other cases, both the covering of the spinal cord and the cord itself protrude from the hole. This condition is called *myelomeningocele* and is a much more serious condition. If there is an open hole, surgical closure of the area is indicated. Spina bifida occurs in approximately 6% of all cases of trisomy 18.

Many babies with trisomy 18 have a condition known as *gastro-esophageal (GE) reflux*. Vomiting may occur when the stomach contents are regurgitated as a result of gastro-esophageal reflux. Common in infants, this condition is usually little more than an inconvenience. However, in babies with trisomy 18, the condition may persist and result in a failure to thrive, blood disorders, apnea, pneumonia and other respiratory diseases.

Feeding was a 24-hour job. Susie would suck two ounces of milk and then fall asleep only to wake hungry a couple of hours later. She would vomit several of her feedings daily. I managed only because I had a very supportive husband who took over when I was too exhausted to wake up at night.

GE reflux may be controlled by positioning, thickening foods, medications and, in severe cases, surgery. Positioning of the child during and after feeding may help control the reflux. It is generally agreed the most effective position is on the back (prone) with the head raised by 30%. When the GE reflux is severe, surgery may be considered. It is essential that adequate preoperative investigation be done to assess whether there are associated problems with GE reflux.

There is a high incidence of hearing loss in children with trisomy 18. Because hearing is so critical to development, parents should discuss early hearing evaluation with their child's pediatrician to determine if this problem is present.



Kyle, 8 years old.

Seizures are a major concern for parents of children with trisomy 18. Approximately 30% of all babies with trisomy 18 experience some seizure activity in the first year of life. These seizures can range from mild *absence (petit mal)* seizures to full *tonic-clonic (grand mal)* seizures.

A seizure is a transient alteration of the brain function. It begins and ends spontaneously and tends to recur. The exact reason children with trisomy 18 have seizures is not known.

The most common type of seizure seen with children with trisomy 18 is the *tonic-clonic* seizure, more commonly called the *grand mal seizure*. This seizure has three distinct phases. In the first phase, called the *tonic phase*, there is generalized stiffening of the body with the arms and legs extended.

Sometimes the baby will make a small cry. Bladder and bowel control will be lost. In the second phase, called the *clonic phase*, the infant will begin to jerk. This will continue for a few moments, then decrease in severity and suddenly stop. The third phase, the *post-ictal phase*, follows the seizure. The child will be very tired and probably sleep.

A less serious type of seizure, and one more difficult to observe, is the absence seizure, also known as the *petit mal*. The typical absence seizure is characterized by the child ceasing all activity and perhaps staring at a fixed point for a few seconds before returning to reality. A *myoclonic seizure* is a brief, sudden contraction of a part of the body which ends as quickly as it begins. *Infantile spasms* occur on occasion, and the baby appears to be reaching up for support or doing a jack-knife dive on the back.

These seizures are not particularly serious in and of themselves. The role of the caregiver is to be sure that the baby's airway is maintained and that the baby is in a position where no injury will occur. It is not necessary to have medical intervention or immediate medical follow-up for such seizures.

A much more serious and potentially fatal type of seizure activity is a condition known as *status epilepticus*, a term used to describe a prolonged, uncontrolled single seizure. You should consult your medical professional about how long a single seizure could last before medical intervention is needed.

Seizures can be particularly difficult for a child with trisomy 18, because some children stop breathing during a seizure and have to be resuscitated. Often seizure activity can be controlled with medication. In any case, it is important you inform your child's neonatologist or pediatrician if your child experiences breath-holding spells, blackouts, unusual repetitive motions or muscle jerks.

Deciding to use medication for Deanne's seizures was a difficult decision. It was so hard to watch for her seizures, but it was worse to do nothing about them. We started the medication the neurologist recommended, and she was seizure free for two years. Whew!

All children with full trisomy 18 will experience severe to profound developmental delays. It is important for parents to understand that no clear prognosis of the child's eventual abilities can be made with standard instruments used to test infants. Most of these tests are merely checklists of developmental milestones. It is impossible to predict from infant testing the degree of delay that may be present.

The term *developmentally delayed*, or the term *cognitively impaired* may be applied in the evaluation of your child. It might be helpful for you to come to terms with the use of these phrases. Realize that in most states, by state law these terms must be used to qualify children for special education. Once you have heard these terms, simply ignore them. It is more important to focus on your child's strengths and milestones passed than to fixate on the label used by the educational system to qualify children for services.



Rebecca, 7 years old.

Cassandra is a strong little girl. She gets infant stimulation as well as physical, occupational and speech therapy. She is doing so well they all ask 'Are you sure she has trisomy 18?' I say, 'Yes. It's hard to believe, because she does so much.'

Since trisomy 18 is a relatively rare condition, it is possible your child's pediatrician has seen very few cases and is relying on information about the condition that has not been updated in the scientific literature. Therefore, it is important for you to understand the type of routine follow-up care you should expect for your infant with trisomy 18. *See Appendix A: Additional Reading.*

Your baby should receive exactly the same type of routine care afforded to every infant. In addition, it is important that cardiac evaluation be completed because of the high incidence of congenital heart defects present with this syndrome. For the same reason, it is important to have an early hearing test. Also, a *scoliosis* check should be a part of each examination.

Since early stimulation and intervention have proven to be extremely effective, particularly in the areas of socialization, it is important to identify infant and pre-school intervention programs in your area.

Chromosomes and karyotypes

Chromosomes are microscopic, thread-like structures present in every cell. Each chromosome contains the genetic material that makes each person an individual. Characteristics of both the mother and father combine to create a unique new individual.

A *karyotype* is a "photograph" of a set of chromosomes arranged in a standardized order. While physicians can often make very good predictions about a genetic disorder

by examining a baby, the diagnosis cannot be confirmed until the child's genetic material is "mapped" in a karyotype.

When an egg and sperm are joined, each brings 23 chromosomes to the resultant new cell that then contains the required chromosomes. The fertilized cell divides repeatedly as the pregnancy progresses, and each division results in a cell that is the exact duplicate of the initial cell.

Every normal human cell contains 22 pairs of *autosomes* (non-sex chromosomes), plus two X chromosomes if the child is a female or an X and Y chromosome if the child is a male.

Figure 1 illustrates normal cell division of a sperm and egg, with only 23 single chromosomes rather than 46 that are found in other cells. For simplicity, one pair of chromosomes is shown in the illustration.

Figure 1: An illustration of normal union and subsequent cell division of a sperm and egg. Only one pair of chromosomes is shown for clarity.

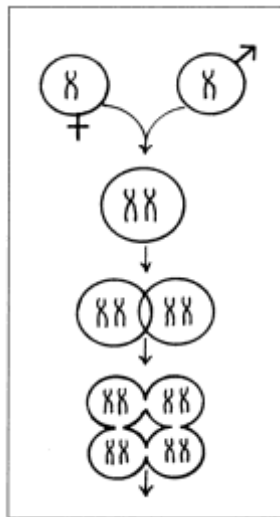

The word trisomy means that three chromosomes are found in a cell in a position that would ordinarily contain only two chromosomes. Trisomy 18 occurs at the moment of conception. This means the trisomy is in the blueprint for the baby's development that is created at the moment of fertilization.

Sometimes, for reasons that are unclear, abnormalities in the number or structure of chromosomes may occur. Trisomy 18 is usually an abnormality of chromosome number in that a complete extra 18th chromosome is present in every cell. The

condition is also known as *Edward syndrome*, named after Dr. J. H. Edward who, in 1960, first described the syndrome in the British medical journal, *Lancet*.

Individuals who have some of the less common forms of trisomy 18 may also have structural abnormalities in the chromosomes. This is true of all disorders called *partial trisomy 18*. In full trisomy 18, the mere presence of three chromosomes in the 18th position creates the pattern of symptoms and medical problems known as trisomy 18 syndrome. The exact way in which the extra genetic material produces the syndrome we call trisomy 18 is unknown.

Usually the error is the result of faulty chromosome division in the formation of the egg or the sperm. The 18th pair of chromosomes fails to separate, leaving one *gamete* (egg or sperm) with 24 chromosomes and the other with 22. At the time of fertilization, this will result in either too many or too few chromosomes. A fetus with a single copy of chromosome 18 will be miscarried; a fetus with three copies is at substantially higher risk for miscarriage but may be born alive.

Figure 2 shows how a *meiotic nondisjunction* (error of chromosome separation in an egg or sperm) results in excess material in the developing embryo.

Nondisjunctional errors can happen with any pair of chromosomes. Most result in miscarriage, although live birth is possible with a few nondisjunctional errors including trisomy 18, trisomy 13 and trisomy 21. Though the cause has not been established, these errors are known to occur much more frequently as women get older. Even though the chance of having a baby with a trisomy increases with age, it is important to note that these disorders can occur at any maternal age. Most babies with trisomies are born to women who are in their twenties, the most frequent child-bearing years.

Figure 2: Meiotic Nondisjunction (error of chromosome separation in an egg or sperm).

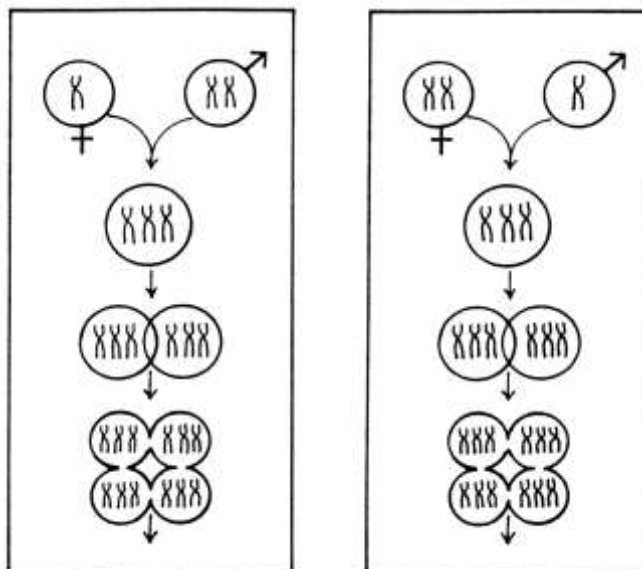

Figure 3: Illustrated is the karyotype of a normal female. Note the XX chromosomes and the 23 pairs of chromosomes.

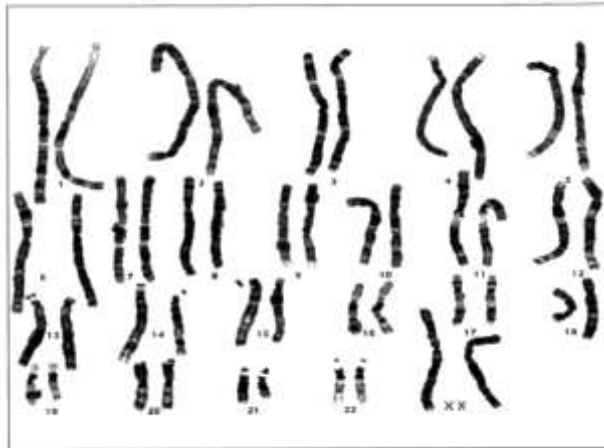
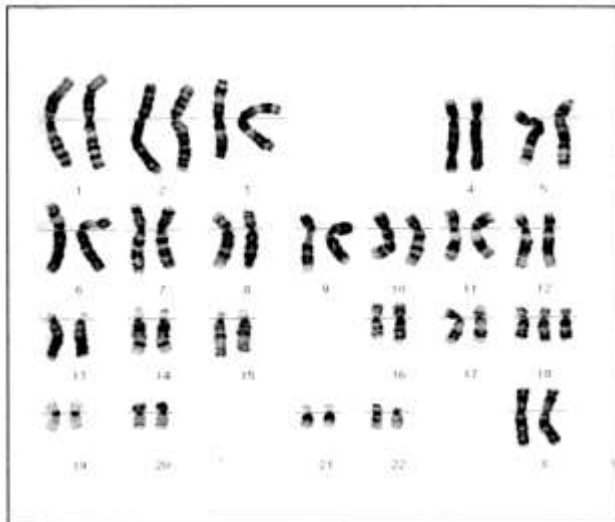

Figure 4: Illustrated is the karyotype of a male child with trisomy 18. Note the three chromosomes in the 18th position.



It is estimated that about 50% of all pregnancies terminate within days of conception and 1 in 5 confirmed pregnancies terminates spontaneously before 12 weeks gestation. It is suspected that many of these natural terminations of pregnancy (miscarriages) are the result of women carrying babies with trisomies, including trisomy 18.

Full trisomy 18 signifies an extra chromosome 18 in every cell in the body. Of the babies who are karyotyped, *full trisomy 18* is diagnosed in approximately 95% of cases. Approximately 2% of the individuals with trisomy 18 have a *partial trisomy*. Most individuals with a partial duplication will have it as part of a complex rearrangement in which an extra piece of the 18 is attached to another chromosome, or even in some

cases, with the 18 itself. The most common of these rearrangements is called a *translocation*. When there is extra 18 material, the condition is an *unbalanced translocation*.

Trisomy 18 *mosaicism* is a rarer form of the syndrome. Mosaic denotes the presence of two types of cells in the same individual, e.g., some with 46 chromosomes and some with 47.

Two possible causes are suspected. In rare cases, the correct number of chromosomes may have been present at conception, but during the first few rounds of cell division one pair of chromosomes failed to separate properly. One of the daughter cells from that *meiotic nondisjunction* would contain a single copy of chromosome 18 and die. The other would contain three copies of chromosome 18 and survive, giving the developing embryo a normal cell line with 46 chromosomes and a second cell line with trisomy 18.

More commonly, an embryo might begin with full trisomy 18 and “lose” one of the extra 18th chromosomes during early cell division. Some individuals with trisomy 18 mosaicism have the full spectrum of symptoms; others have milder or fewer symptoms.

Errors in chromosome division are common and are outside of our control. There is no scientific evidence to suggest that trisomy 18 can be caused by exposure to environmental dangers or X-rays, living an unhealthy life-style, drinking, smoking, drug use, stress, diet or poor parental health. It is important to remember that nothing either parent did or failed to do could have caused or prevented the presence of the extra chromosome 18.



Melissa, 3 years old.

Over the years there have been many problems. Many times I was afraid to open my eyes because I was afraid of what lay ahead. But, I always remember what my mother said to me. When I found our Tammi would be mentally and physically handicapped and the tears would not stop, my mother said, 'Baby, are you crying because your child has a disability or because you have a handicapped child?' Imagine the impact that statement had on me! Then my oldest sister chimed in, 'We will do for this baby the same things we did for all the others...love her, feed her and see she gets the best we have to offer.' From that moment, this has been my motto.



The Marro family

Prenatal diagnosis through *amniocentesis* or *chorionic villus sampling* is an option for parents who have had a child with any form of trisomy. In future pregnancies, families can consult their physician or genetic counselor about the details of this option.

All of this information may seem somewhat bewildering to parents facing the crisis of giving birth to a baby with trisomy 18. After reading this material, it is likely you will have many questions. It may be necessary to have the information explained several times before you understand it completely.

Let your physician know what you do and don't understand about your child's genetic makeup and medical condition. *If you do not understand the answers to your questions, ask them again. Be persistent!*

What are the educational opportunities for your child?

With more and more babies surviving the first years, we are seeing the need for early and continuing special education services. This section of the guidebook will assist you in understanding your rights as parents of a young child with disabilities and to introduce you to some of the special education and related services that may be available for you, your child and your family.

Three pieces of federal legislation form the framework for providing the special education services needed by children with trisomy 18. Public Law 94-142, passed by Congress in 1975, requires that special education services be made available to all school-age children with disabilities.

Public Law 99-457, and later the Individuals with Disabilities Education Act (IDEA) of 1990 extended this mandate down to three years. Infant and toddler services from birth to age three are available in most states, though not always through the State Department of Education. However, the leading state officer in education will be able to direct parents to the proper agency for infant services. In December, 2004, the Individual with Disabilities Education Improvement Act (P.L. 108-446) was signed into law, thus ensuring continuing educational services for young children with disabilities. The diagnosis of Trisomy 18 makes your child eligible for free appropriate early intervention services. The providers of services for children from birth to age three may vary from state to state. Often the provider may be a health or welfare entity rather than the public schools. Parents are advised to contact their local school district director of special education or the state director of special education for guidance to services in your particular state.

Leslie has been getting therapy since on month of age. I took her twice each week to Children's Hospital for three years. Then the public school system took her. She was in an all-day program at the school. She progressed from a very tight child to a child who can sit alone and is doing a little standing and holding on to a chair. She is transported to and from school on the bus in a travel wheelchair.

These federal laws acknowledge that all children can profit from educational intervention and that no child shall be found ineligible because of the severity of the disability. These laws also provide specific regulations regarding parents' rights in all aspects of the educational process and provide an appeals process for parents if they disagree with the professionals. These rights pertain to parent input in assessment, program planning, determination of eligibility and placement decisions.

Every school district **must** make special education services available to all children with disabilities from three through 21 years of age. Early intervention services **may** be available in your state for children with disabilities from birth to three years of age. Many new parents do not understand what is meant when educational professionals discuss *early intervention*. Early intervention simply means that rather than waiting until your child is school-aged, the educational system realizes that interaction and teaching at a much earlier age offers tremendous benefits to both parents and children. Early intervention services can start before the child leaves the hospital nursery.

An example of an early intervention service that could be provided in the nursery is an occupational therapist working with you to show you how to hold and feed your baby. Early intervention services in the first two years often include home visits by specialists to work with you and your baby. The focus of these interventions is determined jointly by you and the early intervention specialist.



Depending upon your baby's needs, several different specialists such as a physical therapist, speech pathologist and teacher might work with you. The main purpose of early intervention is to provide you and your family with services that help your baby to develop basic abilities.

I had never heard the term 'infant stimulation' before but I was excited to learn how to finally help my daughter. What I didn't know then, but see clearly now was the

interaction with Kristi was as good for me as it was for her. As Kristi gained skills, I gained confidence. We made a great team!

There is strong evidence that early intervention increases social skills and the child's integration into the family setting. Services for infants and toddlers are usually provided in your home, although some specialized services may be available only in center-based settings. Services for pre-school age children are usually center-based, including regular, community-based pre-school and child care settings near your home.



Megan, age 4 years.

The important thing to remember is that special education services **are** available for **all** children from ages three through 21, and that infant intervention programs are available in your state. Early intervention services and related family support services in general are provided at no cost to the parent, and there are no income eligibility requirements.

Every state has a designated public agency responsible for providing early intervention services. The lead agency in your state may be your state department of education, health or social services. If you do not know which agency to contact, check with your pediatrician, hospital, local health department or the director of special education in your local school district.

Early intervention services usually include a complete developmental assessment and determination of your child's eligibility for services. Remember, the diagnosis of trisomy 18 automatically qualifies your child for the services provided in your state. You will be invited to meet with the specialists who will provide findings from their developmental evaluation of your child. You have the right to be a participating member of this team. You will be asked to provide your opinion about your child's immediate and long-term needs for learning and development.

If you disagree with the results of the initial assessments or with the identified needs of your child, make your opinions known. Developing an *Individual Family Service Plan*, or *IFSP* (ages birth to three) or an *Individual Educational Plan*, or *IEP* (ages three to 21), can be overwhelming for parents. While the “experts” will tell you what your child needs, remember you are the ultimate expert. Make your feelings known.

As a parent of a child with trisomy 18, you will work closely with agencies providing early intervention and special education services. All parents need to know their opinions are as important as those of the professionals. Parents’ rights are very clearly spelled out by the law. If you are uncertain about what the professionals are telling you about your child, ask them again. If you disagree with their decisions, persist in explaining your concerns.

If you cannot reach agreement with the professionals about your child’s educational needs, you have specific rights under the law. In every state there is an agency responsible for providing free professional and legal support, counseling and advocacy services for parents of children with disabilities. Often these agencies are staffed by parents of children with disabilities.



Stacy, 12 years.

In states that provide early intervention for children with disabilities from birth to three, a variety of services related to the special needs of your child could be offered.

This could mean the development of an Individual Family Service Plan (IFSP) for your family and your child. Managing the needs of a child with trisomy 18 often involves ongoing contact with several physicians and others in the hospital, consultation with specialists, diagnostic work-ups, and dealing with a variety of medical, surgical and health-related issues.

In addition, you may be working with your insurance company, Social Security, and other public and private service agencies. Service coordination, also provided at no cost to you, is a part of early intervention services. You also may request services for your family as a part of early intervention for your child. These services may include counseling, respite care or additional information about trisomy 18 for family members.

What is your role in early intervention? Some parents like to be very involved in teaching new skills to their child and work closely with the early intervention specialists. Some parents would rather spend their time involved in whole family activities and prefer that the specialists teach their children. The “most appropriate” role in early intervention for you is the role you feel most comfortable assuming.



Joseph, 9 years.

Services could include working on your child’s social skills, particularly in teaching your child how to interact with others. Depending on your child’s specific needs, there also could be programs aimed at the development of language and physical, cognitive and self-help skills. Additionally, early intervention services may be provided to help you understand your child’s strengths, weaknesses and developmental needs.

Joseph has started school one morning a week and seems to like it pretty well. He also gets homebound physical and occupational therapy and a teacher the other days of the week along with private speech therapy. If he does well in the classroom setting, he’ll get more days in school and less homebound schooling.

When your child reaches the age of three, your child is entitled to a free, appropriate public education under the Individuals with Disabilities Education Act (IDEA). This includes, but is not limited to, educational services, speech pathology, physical therapy, transportation, occupational therapy and medical services (including vision and hearing) as needed to allow your child to attend school. All of these services are at no cost to parents.

Each child eligible for special education services has a written Individual Education Plan (IEP) specifying the services, placement, evaluation, and programming designed to help your child reach his/her potential. A multidisciplinary team composed of a school district representative, the child's teacher, members of the diagnostic team, and parents meets to establish goals and write the IEP.

When we received notification of Tricia's IEP meeting, I looked at all the professionals' names and positions. I felt inadequate compared to all the degrees who were going to sit around the table. When I expressed my feelings to my husband, he said, 'You have something that no one else in that room will have . . . a mother's intuition. You don't need anything else so use it.' He was right and I did!

It is important to understand that these are educational rights. Every school district in the country is required to provide services to children with disabilities regardless of available resources. Lack of funds or personnel is no excuse to withhold special education services.

I'll never forget the feeling of sending Kari to school on a bus. It seemed crazy I would send a little child to school who needed to be strapped into an infant seat. Yes, I followed the bus to school to make sure she got there safely. Kari was fine, but I was a wreck.

Each state has a director of special education housed in the state department of education. If you have questions or concerns that cannot be addressed at the school district level, you may pursue them with the state department of education. If you still do not receive satisfaction, you may institute a due process procedure.

In any case of dispute, be sure to communicate with other parents who may have gone through similar situations. Faculty in the special education department at your nearest college or university are also available to give you information about your rights.

Kenny attends school in our 'regular neighborhood school.' And yes, it was a struggle to get that. His school is five minutes from home. Kenny is in a multi-categorical classroom – 4th grade. He goes to physical education with his 'normal' peers. He also goes to art and music. Kenny goes to the lunch room with all the kids, and then all of the kids go to recess. He thinks the keyboard in music class is just the greatest, so we got him his own for his 9th birthday.

What else do we need to know?

All children with trisomy 18 experience from moderate to severe physical problems necessitating frequent visits to the physician and often, multiple hospitalizations. As a parent, you may feel that some of the treatments your child is receiving as an inpatient in a hospital might better be provided at home. During a phone-in session to then President Ronald Reagan, one family complained to the President that they had to leave their child in the hospital in order to qualify for Medicaid, while the services the child was receiving could have been provided at home. President Reagan's response was creation of the Home Care for Certain Disabled Children program, more familiarly known as the Katie Beckett Program for the child and family involved.



Lyndsey, 2 years.

Katie Beckett funds are Medicaid waivers which are state-run programs that use federal and state funds to care for people with certain health conditions. Medicaid waivers permit states to use flexibility to design publicly-financed health care systems outside of certain federal Medicaid statutory and regulatory requirements. Each state has different waivers with different requirements. For general information, see <http://www.familyvoices.org/> and enter "Katie Beckett" in the search box. Specific information about the Social Security Administration's federal Maternal Child Health (MCH) ("Title V") program, which created The State Program for Children and Youth with Special Health Care Need (CYSHCN) is available there, as well as the Katie Beckett story. For specific information about Katie Beckett funds in your state, contact your state director of special education.

When you became pregnant, you assumed you would have a “normal” child. This did not happen. Now, you may feel a desperate need to know what is “normal” for your child.

The scientific literature will not necessarily give you the information you seek. The area of pediatric medicine grows and changes dramatically every day. It is impossible to project today what medical science will know in five years. But there are some things we do know that might help you come to understand your baby better.

Our little D.J. was a very special child. She brought so much joy to our lives. You could see so much life in her little sparkling eyes. She had a smile that said, ‘I love you.’

There is a misconception that your child will not know you, will not have any personality and will be a “survivor” devoid of personality. Those of us who have known a child with trisomy 18 know this is not true. Even though most children with trisomy 18 have severe to profound delays, each certainly has an individual personality.

In spite of the many problems, our daughter Melissa, who’s two years old, is such a happy little girl. Her smiles and laughter make our hearts melt. Even her big brother, Michael, who’s four years old, likes to put on a show for her.

Since there is little current information available in the scientific literature regarding survival rates with advancing medical intervention, there is a very good chance you will hear only negatives from your medical care provider. While to some degree this is reality, it is also true that the child’s potential may be markedly underestimated.

Nathaniel will be six years old in March. He has learned many new things. He imitates a bye-bye wave, claps his hands to music, makes na-na sounds uses a computer with an adapter switch, plays with his new puppy, and just almost sits up by himself. We have enjoyed watching his progress and set new goals for him each day.

Parents often live with a chronic, anticipatory grief surrounding the potential loss of a child with trisomy 18. However, several children known to SOFT, with trisomy 18, are alive and well or have lived into their 30’s. The length of time you will have with your child will be, in large part, dependent on the life-threatening conditions your child experiences.

Those seven months we had with Derek are so precious. We try to remember his sweet little smile and how he continuously tried to get his thumb in his mouth for sucking. He loved to look at his mobile and reach for it. Every little thing he did was a milestone and made us very proud. He brought us smiles to our faces and sometimes tears to our eyes, tears of joy and love.

Every family accepts the baby with trisomy 18 in its own way. Older siblings have waited anxiously for the birth of the new baby, and often may not understand what

has happened when they are told the new baby may not live long. Having a child with a disability also puts a major strain on the marriage and the family unit. Other children in the family may not understand why the parents are so distressed. In a very real sense, their safe and secure world will never be the same again.

Mummy was going to have a baby. The whole family was excited, me especially. All of my friends had baby brothers and sisters and I couldn't wait to hold and play with our baby. My little sister arrived and we named her Beth. But Mummy kept crying and Daddy was sad because Beth was very sick.

Siblings of babies with trisomy 18 may find going back to school a difficult experience. While they are very sad, they do not wish to show their grief in front of their peers. Yet everyone needs to have an outlet for grief and a way to share feelings. Often someone outside of the immediate family, such as a relative or close friend, can serve as a confidant for the sibling of a child who is very ill or has died. But just as families share their joys, it is also important they be able to share their sadness and support one another. It is important that parents share their grief with the rest of the family. Children need to know that expressions of sadness and anger are part of the grieving process.

After my baby sister died, it was horrible going to school. I just wanted to stay at home. One teacher was especially nice. I used to go to her whenever I was upset and she would give me a drink and a cookie.

The pain of grief is hard to endure, but it is important family members go through the grieving process in their own way. For parents who gave birth to babies with severe disabilities, the grieving process may need to be completed twice; once when they grieve for the "normal" child they expected did not have and again if their baby dies. We would all like to hold on forever and not let go, but there comes a time when we must let go.



Mark, 8 months.

Lauren's cereal bowl is still in the kitchen cupboard. The smocked dress she received for her birthday and was going to wear for Christmas still hangs at the side of her crib, never worn. One of these days I'll pack up these things, but not just now. Maybe that's because putting her things away will make everything so final, and I'm just not ready to do that yet.

Often parents need to be alone together. Finding a child care provider who can cope with the special needs of an infant with trisomy 18 can be difficult. However, most communities provide respite care through health and social service agencies. In some areas, senior citizen groups such as Foster Grandparents provide care for children with disabilities. Cost, length of stay and availability will vary widely from one area to another. Ask for information on the availability of child care from your pediatrician or care givers at the hospital before you take your baby home.

We held Katie for two hours after she died. Our family came to the hospital to be with her. It was so special.

Because of the serious nature of the physical disabilities that accompany trisomy 18, parents are often asked to participate in life or death decisions about the baby at the precise time when they are least able to cope emotionally. Do you use heroic means to prolong life? Do you provide surgeries that will sustain life? Do you withhold drugs and therapies that might prolong life? Do you agree to have major surgery involving a general anesthetic even though administration of such an anesthetic might be a danger to the baby? These are all questions parents may face.



Mark, 11 months.

The most important thing to remember is that no matter what decisions you and your medical team reach, you have done the best you can in the situation. There are no “correct” answers to these questions. The decision not to give intensive care to prolong the life of a very ill baby does not mean that loving care is withdrawn.

The doctors gave us a choice. We could have Melissa taken off the respirator and watch her die or we could keep her on and see what would happen. We decided we wouldn't give up on her, and we would support her medically as much as she needed. We knew in our hearts if we didn't give up hope, neither would Melissa. Day after day, the doctors put new time limits on her life and each day she would outlive them.

.....

Appendix A

Organizations

A number of organizations exist to assist parents and families going through the grieving process. Perhaps the most pertinent for parents of children with trisomy 18 is SOFT, the Support Organization for Trisomy 18, 13 and Related Disorders. The group recognizes the need for support and information beyond what is available from the family's medical team. The SOFT on-line newsletter, *SOFT Times*, is produced four times a year and contains letters from parents of children with trisomy, information on emerging medical trends and articles written by professionals on special care required by children with trisomy. SOFT also sponsors an annual international conference that includes special sessions for families grieving the loss of their child. Registration with SOFT is free although donations to help with operating costs are always welcome. SOFT can be contacted as follows:

Barb VanHerreweghe
2982 South Union Street
Rochester, NY 14624
800-594-4621 or 800-716-7638
FAX: 585-594-1957
Email: barbsoft@rochester.rr.com
Website: <http://www.trisomy.org>

Another organization helping parents and families cope with the death of a child is The Compassionate Friends. The Compassionate Friends is a national support group with chapters in many communities. A newsletter and other publications are available. The national office address is:

The Compassionate Friends
P.O. Box 3696
Oak Brook, IL 60522-3696
630-990-0010 or 877-969-0010
Email: nationaloffice@compassionatefriends.org
Web site: www.compassionatefriends.org

If you are interested in genetic counseling, contact the National Center for Education in Maternal and Child Health (NCEMCH). NCEMCH counselors can direct you to agencies for educational, financial, medical and psychological help as well as identify the genetic counseling center nearest your home.

**National Center for Education in Maternal
and Child Health**

Georgetown University
2000 N. 15th St., Ste 701
Arlington, VA 22201-2617
202-784-9770

The National Organization for Rare Disorders (NORD) makes referrals to parent and support groups, produces a newsletter and provides scientific articles on specific diseases.

National Organization for Rare Disorders

P.O. Box 8923
New Fairfield, CT 06812
203-746-6518 or 800-999-6673

Additional Reading

The SOFT website provides a lengthy list of professional, peer-reviewed articles and literature produced by SOFT members. These can be found at the “Book Store” section of the SOFT website or in the “Professionals” selection of the website’s main menu. <http://trisomy.org>

Palomaki G.E., Deciu C., Kloza E.M., et al. 2012. DNA Sequencing of Maternal Plasma Reliably Identifies Trisomy 18 and Trisomy 13, as well as Down Syndrome: International Collaborative Study. *Genetics in Medicine* 14:296-305.

Carey J.C., 2005. Health Supervision and Anticipatory Guidance for Infants and Children with Trisomy 18 and 13 updated from 1993 *Trisomy in Review, Trisomy 18, 13 and Related Disorders, Research Newsletter* (SOFT)

Surgery & Growth Summary. A compilation of surgeries reported by SOFT parents. Growth & weight charts. Baty et al, 1994 Natural history of trisomy 18 and 13: I. Growth, physical assessment, medical histories, survival and recurrence risk. *Am J Med Genet* 49: 175-188. Note: Updated surgery information is separately available on the SOFT web site.

Barnes, A.M. & Carey, J.C. (2008) *Care of the Infant and Child with Trisomy 18 or Trisomy 13: Medical Problems, Reported Treatments and Milestones*. Rochester, NY: SOFT (2008 print book). An e-Pub version, updated in 2014, is also available from the SOFT website.

Barnes A.M. & Carey J.C. (2012) *Common Problems of Babies with Trisomy 18 or 13*

Glossary of Terms

Words which may be used in association with trisomy 18. In addition to these, a list of terms with links to explanation can be found on the SOFT website, at:

http://trisomy.org/?page_id=8938

absence – non-generalized seizure. Brief and abrupt loss of consciousness associated with clonic motor activity ranging from eyelid blinking to jerking of the entire body. Sometimes no motor activity is observed.

amniocentesis – removal of a small amount of the fluid surrounding the fetus in the uterus for prenatal diagnosis or other reasons.

anomaly – a variance from the normal.

apnea – periods of interrupted breathing or breath holding.

atrial septal defect (ASD) – a hole between the two upper chambers of the heart that makes it difficult for the heart to pump sufficient oxygen-rich blood to the body's tissues; a heart murmur can be heard.

auditory brainstem-evoked response – a test to determine if the hearing system can transmit information about sound to the brain.

autosome – one of the numbered, non-sex chromosomes.

balanced translocation – chromosome rearrangement seen in the karyotype but all the genetic material is present.

cell-free DNA testing - Cell-free DNA fragments are short fragments of DNA found in the blood. During pregnancy, there are cell-free DNA fragments from both the mother and fetus in maternal circulation. It is possible to analyze cell-free DNA to detect common fetal trisomies.

chorionic villus sampling – a test used to diagnose chromosomal abnormalities prenatally.

chromosome – a very small piece of dark-staining material within the cell, made up of DNA and proteins, which “carries” the genes.

cleft lip and palate – a gap in the soft palate and roof of the mouth, sometimes to the upper lip.

disability – a physical or mental impairment that substantially limits major life activities such as caring for one’s self, performing manual tasks, walking, seeing, hearing, breathing, working or learning.

dorsiflexed – when a toe or finger is bent backward.

gastrostomy – an artificial opening into the stomach for feeding purposes.

gavage – a method of feeding the child through a tube inserted through the nose and into the stomach.

gene – the portion of the DNA of a chromosome that contains the information needed to make one polypeptide chain. Polypeptide chains are linked together to form proteins.

Individual Family Service Plan (IFSP) – a plan devised by the family and educational professionals to best meet early intervention needs of infants with disabilities or at risk.

Individual Education Plan (IEP) – a plan developed by parents and educational professionals to meet the educational needs of children with disabilities, ages 3-21.

infantile spasm – progressive disorder in infants with motor spasms or other convulsive signs. Infant may go into a “jack-knife” position.

karyotype – the photograph of a set of chromosomes arranged in a standardized order.

meiotic nondisjunction – an error of chromosomal separation in the egg or sperm.

meninges – the three membranes enveloping the brain and spinal cord.

meningocele – protrusion of the meninges or covering of the spinal cord through an opening in the bony spinal canal.

microcephaly – a condition in which the head is abnormally small.

mosaicism – in an individual, the presence of cells with different chromosome constitutions.

myoclonic seizure – brief, sudden contraction of a part of the body that ends as quickly as it begins.

myelomeningocele – protrusion of the spinal cord and its covering through an opening in the bony spinal canal (same as spina bifida).

neonatal intensive care unit (NICU) – an area in the hospital designed to offer intensive care to newborns with severe problems.

non-invasive prenatal testing (NIPT) – see cell-free DNA testing.

non-disjunction – the failure of chromosome pairs to separate correctly during division, resulting in an abnormal number of chromosomes in the cells.

partial trisomy – when a pair of a particular chromosome and an additional piece of a third chromosome are present in an individual.

patent ductus arteriosus (PDA) – a congenital heart defect in which closure of a duct fails to occur, resulting in abnormal direction of blood flow.

polydactyly – extra fingers and/or toes.

post-ictal phase – final phase of a generalized tonic-clonic seizure, characterized by disorientation and depression of central functions.

prenatal diagnosis – the detection of specific genetic disorders prior to birth through techniques such as amniocentesis and ultrasound.

respite care – short-term care given to an infant or child with disabilities by an outside person or agency to provide a break for parents.

retinal dysplasia – a faulty development of retina in the eye.

scoliosis – a lateral or side-to-side curvature of the spine in the shape of the letter “S.”

sex chromosome – the X and Y chromosomes that determine the sex of an individual.

spina bifida – a condition in which part of the spinal cord covering, or the cord and its covering, protrudes through an opening in the bony spinal column (same as myelomeningocele).

status epilepticus – prolonged, uncontrolled single seizure; may be fatal without medical intervention.

syndactyly – webbed fingers and/or toes.

tonic-clonic seizure – generalized seizure with major convulsions, usually a sequence of maximal tonic spasm of all body musculature followed by clonic-jerking and prolonged depression of all central functions.

translocation – attachment of part or all of one chromosome to another chromosome; in some cases pieces of chromosome material “trade places.”

trisomy – when three of a particular chromosome, rather than the usual pair, are present in body cells.

ultrasound – a computerized method of viewing internal organs through the use of sound waves to create a picture similar to an X-ray.

unbalanced translocation – extra and/or missing chromosomal material due to a rearrangement. This may be inherited from a parent who has a balanced translocation.

ventricular septal defect (VSD) – a hole between the two lower chambers of the heart that prevents the heart from pumping blood correctly; a heart murmur is generally heard with this congenital defect.

.....